

DETERMINATION OF HEATS OF DETONATION AND INFLUENCE OF COMPONENTS OF COMPOSITE EXPLOSIVES ON HEATS OF DETONATION OF HIGH EXPLOSIVES

Y. Tongchang, Y. Menchao and W. Jianling

Xian Modern Chemistry Research Institute, Xian 710061, P. R. China

(Received November 25, 1993; in revised form July 4, 1994)

Abstract

The heats of detonation of 20 simple high explosives and explosive mixtures were determined by means of an adiabatic detonation calorimeter designed by the authors. The results indicated that the performance of the instrument was reliable and the experimental data were very accurate. For explosive mixtures, there was a linear accumulative relationship between the heats of detonation of the explosive mixture and its components. Accordingly, the heats of detonation of explosive mixtures could be calculated directly from the heats of detonation of simple explosives and the characteristic heats of other components. The experiments showed that the gold or brass shell of the cylindrical charge could be substituted by a thick-walled porcelain shell, which had the advantage of cheapness.

Keywords: adiabatic detonation calorimeter, explosive mixture, heat of detonation

Introduction

The heat of detonation is known to be an important parameter in evaluations of the performance of explosives. Research in this area began in the 1940-s, and the heats of detonation of cyclotrimethylenetrinitramine (RDX) with different densities were obtained by Apin and Lebedev [1]. Later, Pepekin *et al.* reported the heats of detonation of 16 simple explosives with two kinds of density [2]. Meanwhile, Lebedev *et al.* had reported a series of heats of detonation of water-containing or alumina-containing explosives [3]. From 1966 on, Ornellas *et al.* had measured a series of heats of detonation of explosives [4-8], most of which were simple explosives. Nowadays, explosive mixtures are widely used. Accordingly, it is very timely and important to study factors influencing the heats of detonation of explosive mixtures and to measure the heats of detonation of explosive mixtures exactly.

Additionally, an inert metal (gold or brass) shell is usually used in high-accuracy experiments [3–6], but the experiment is then very expensive. In our laboratory, the shell was made of cheap porcelain to substitute the inert metal shell.

Experimental

Materials

2,4,6-Trinitrotoluene (TNT), RDX, cyclotetramethylenetetranitramine (HMX), pentaerythritoltetranitrate (PETN), C-4 and desensitized RDX were commercial products. 1,3-Diamino-2,4,6-trinitrobenzene (DATB) was prepared, purified and dried in our Institute.

PBXN-5, LX-07, LX-04, LX-11 and O/F were explosive mixtures of HMX with 5%, 10%, 15%, 20% and 40% fluorinated rubber, respectively. The fluorinated rubber was F₂₆₋₄₁, a copolymer of meta-bifluoroethylene and perfluoropropylene.

Cyclotol and Pentonite were explosive mixtures of ground RDX or PETN, respectively, with TNT. All materials were pressed to form a cylindrical charge with a diameter of 25 mm.

Thermosetting explosive consisted of HMX and nylon in a mass ratio of 86:14. Pellets were prepared by machine after vulcanization in a model.

Rubber explosive was made of HMX and polyisobutene (PIB) in a mass ratio of 86:14. It was a special charge with a high content of rubber, to study the influence of PIB on the heat of detonation. The desensitized RDX consisted of RDX and desensitizer in a mass ratio of 95:5. HVG-16 was similar to LX-07, containing 1% graphite. Hexal consisted of RDX, aluminium and desensitizer in a mass ratio of 66:30:4.

Apparatus

The adiabatic detonation calorimeter designed by ourselves is depicted in Fig. 1.

The jacket and its lid was double-layered, and contained distilled water in which some electrolyte mass dissolved. The water could be circulated between the jacket and the lid of the jacket by means of a pump. There were a snake cooler pipe and a heater in the jacket. Ion conduction heating was used to decrease the heat inertia.

The cylindrical bomb of the calorimeter, constructed of alloy steel, had an internal volume of about 5 l. The bomb could withstand a pressure of 200 MPa, and experiments could be carried out with a maximum of 50 g of high explosive.

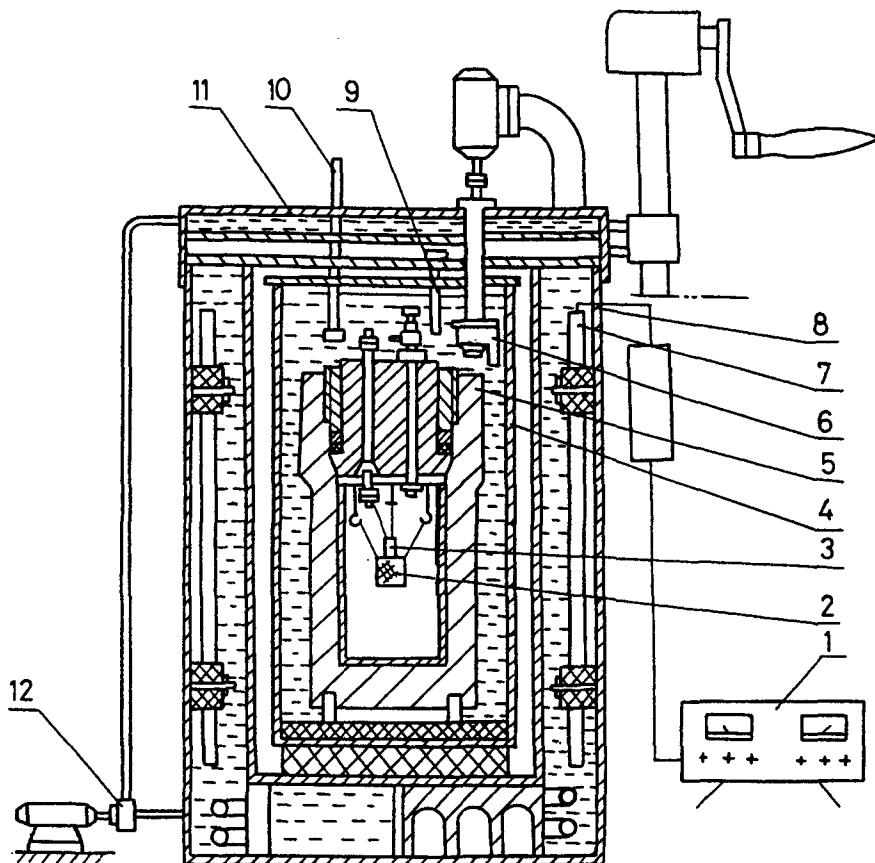

Fig. 1 Scheme of the adiabatic detonation calorimeter; 1. Temperature controller; 2. cylindrical charge; 3. detonator; 4. bucket of calorimeter; 5. bomb; 6. diving pump; 7. heater; 8. jacket; 9. platinum resistance; 10. probe of quartz thermometer; 11. lid of jacket; 12. pump

About 14 kg of weighed distilled water was added to the cylindrical bucket of the calorimeter. Since there was a distance of only 20 mm between the bucket of the calorimeter and the bomb, a nylon diving pump had to be installed on the upper part of the bomb instead of the normal stirring machine. The pump mouth was directed to the space between the bomb and the inner wall of the bucket, and let water reach the bottom of the bomb through the space. The experiments indicated that the water in the bucket circulated very well.

The equivalent of the instrument was about 130 kJ/deg and the temperature was increased by about 1~1.2 deg when a 25 g charge was measured, so a quartz thermometer with a graduation of 0.0001 deg could be used.

Two 100 Ω platinum resistances linked by a temperature controller were installed in the jacket and the bucket. The temperature of the jacket could be con-

trolled by an auto-follow temperature controller so as to allow the temperature changes of the calorimeter bucket to be followed. The maximum heating current was 60 A.

Procedure

The pellet was pressed to a diameter of 25 mm and weighed to the nearest 0.1 mg. This pellet was put into a porcelain shell with a wall thickness of 8 mm and an internal diameter of 25 mm, then suspended under the lid of the bomb. The connection was made with the detonator, the lid of the bomb was covered, air was pumped from the bomb until vacuum was attained, and purified nitrogen was forced into the bomb until the pressure reached 1 MPa. The nitrogen was next released, the bomb was then pumped out, a vacuum was again created, and finally the valve was switched off firmly. The bomb was placed in the calorimeter by means of a crane and the weighed distilled water was added. The water surface should be higher than the top of the bomb. The detonating cord was connected with the bomb and the lid of the calorimeter was covered. The pump in the jacket and the diving pump were then switched on to keep the temperature of the water in the bucket and in the lined jacket uniform. After 1 h, the temperature controller was switched on and its balance knob was adjusted until the water temperature change in the bucket was not more than 0.003 deg within 15 min and the temperature (T_1) was recorded. The sample pellet was then detonated. After 1 h, the temperature of the water in the bucket of the calorimeter was observed until the change in temperature was not more than 0.003 deg within 15 min. The temperature (T_2) was then recorded and the pressure of the gaseous product of the explosion (P) was measured by means of the pressure gauge connected to the valve of the bomb. The heat of detonation could be calculated via the following equation:

$$\Delta H_{\text{det}} = \frac{W(T_2 - T_1) - Q_d}{m} - \frac{PV}{m} \quad (1)$$

where ΔH_{det} heat of detonation of pellet, kJ/g;

W equivalent of the instrument, kJ/deg;

Q_d heat of detonation of the detonator, kJ;

m mass of sample, g;

P pressure inside the bomb after the detonation, MPa;

V volume of the bomb, l.

The equivalent of the instrument was obtained by burning the standard benzoic acid. The heat of detonation of the detonator was obtained by running blank experiments with 20 detonators.

Results and discussion

Influence of shell on heat of detonation

The shell wall thickness has a great effect on the experimentally measured heat of detonation. Table 1 shows the influence of the brass shell wall thickness on the heat of detonation.

Table 1 reveals that, the thicker the shell, the greater the heat of detonation (up to a brass shell wall thickness of 4 mm).

Table 1 Heat of detonation of TNT for different brass shell wall thicknesses

Brass shell wall thickness (mm)	0	2.0	4.0	5.0
Heat of detonation, $\Delta H_{det}H_2O(1)$ (kJ / g)	2.55	4.30	4.37	4.38

Most explosives consisting of carbon, hydrogen, oxygen and nitrogen exhibited a negative oxygen balance. A low oxygen content does not allow the ignitable elements (C and H) to be oxidized fully (to CO_2 and H_2O), and the following reactions then occurred during detonation:

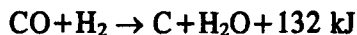
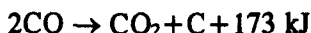

During the moment of detonation, these two reactions shifted to the right under the pressure of several ten GPa, so more carbon dioxide, water and heat were produced. During the gas expansion in the bomb, the pressure fell rapidly, but the heat could not be conducted to the outside immediately, and the above two reactions shifted so as to be left under lower pressure and higher temperature, and partial heat was absorbed when the balance shifted, which resulted in the measured heat being lower.

For measurement of the heat of detonation exactly, an inert shell was used to reduce the reaction shift. Under this condition, as the charge was detonated, the heat could be absorbed by the broken shell, which resulted in the temperature of the product being lowered and the reaction rate being reduced, so the above reactions could not shift to the left. The measured heat was near the exact heat of detonation.

As inert metal shell, for example, a brass shell with a wall thickness of 4–7 mm was used in Russia [1–3], and a gold shell with a wall thickness of 12.7 mm was used in the USA [4–7]. Both of them had the disadvantages of expensive cost and of damage to the bomb wall by broken metal, which resulted in the life of the bomb being shortened. The porcelain shell had the advantages of brittleness and inertia. It could not react with the detonation products, and

could be blasted into powder, which did not damage the bomb wall. We studied the influence of different wall thicknesses of the porcelain shell on the heat of detonation (Table 2). Table 2 also lists data obtained with a brass shell.

Table 2 demonstrates that the heat obtained from the charge with a porcelain shell with a wall thickness of 6–8 mm equalled that from the same charge with a brass shell with a wall thickness of 4 mm. Accordingly, a porcelain shell with a wall thickness of 8 mm could be used.

Table 2 Influence of shell on heat of detonation

Explosive	Density/ g·cm ⁻³	Material of shell	Shell wall thickness/ mm	Heat of detonation $\Delta H_{\text{det,H}_2\text{O}}(1) / \text{kJ}\cdot\text{g}^{-1}$
TNT	1.58–1.59	Porcelain	4	4.31
			6	4.36
			8	4.40
			11	4.38
		Brass	4	4.37
			5	4.38
PETN	1.57	Porcelain	6	6.19
			8	6.24
		Brass	5	6.30
RDX	1.64–1.66	Porcelain	8	5.87
		Brass	4	5.95

Influence of density of pellet on heat of detonation

The heat of detonation was affected by the density of the pellet. The influence was closely related to the oxygen content of the explosive. For an oxygen-deficient explosive, the higher the density, the higher the heat of detonation; the more negative the oxygen balance in a charge, the greater the influence on the heat of detonation. Data on two oxygen-deficient explosives for which the heat of detonation is affected by density are listed in Table 3.

The influence of density on the heat of detonation results from the high pressure in the bomb, which affects the reaction equilibrium. The higher the density of the pellet, the higher the pressure, and the above equilibrium is shifted readily to the right. This indicated that the density of the pellet should be similar for the same charge; the difference should not be more than 0.02 g/cm³. The pellet of high explosive should have a higher density, but a pellet density of about 1.0 g/cm³ for an industrial charge should be controlled generally.

Table 3 Influence of pellet density on heat of detonation

Explosive	Oxygen balance	Density/ $\text{g}\cdot\text{cm}^{-3}$	Heat of detonation $\Delta H_{\text{det,H}_2\text{O}}(1) / \text{kJ}\cdot\text{g}^{-1}$
TNT	-74.0%	0.83	3.27
	-74.0%	1.59	4.44
RDX	-21.6%	0.81	5.50
	-21.6%	1.64-1.66	5.81

Heats of detonation of common high explosives

Some common high explosives were studied, and their heats of detonation are listed in Table 4, which includes literature data for comparison.

The results indicated that the heat of detonation for jacketing with a porcelain shell was near to that for jacketing with a gold shell.

Linear accumulative relationship between heat of detonation and fluorinated rubber content

The relationship between the heats of detonation of HMX/fluorinated rubber explosive mixtures and the fluorinated rubber content is shown in Fig. 2.

It may be seen from Fig. 2 that there is a linear relationship between the fluorinated rubber content and the heat of detonation of the charge. The higher

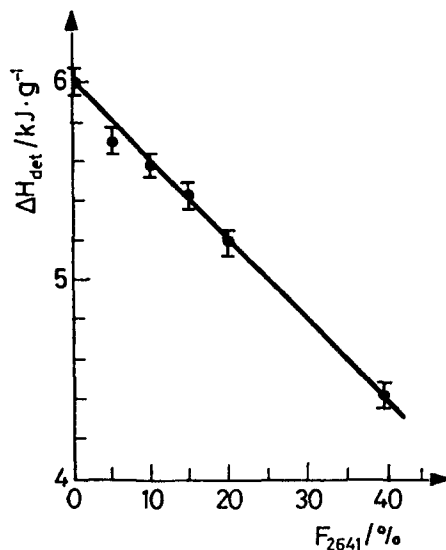

Fig. 2 Relationship between heats of detonation of HMX/fluorinated rubber explosive mixtures and fluorinated rubber content

the percentage of the rubber, the lower the heat of detonation of the charge. A one percent increase of the rubber content resulted in a decrease of about 40 J/g in the heat of detonation.

A plot of the heats of detonation of TNT/RDX explosive mixtures vs. the percentage content of TNT is depicted in Fig. 3. A linear relationship was found here too.

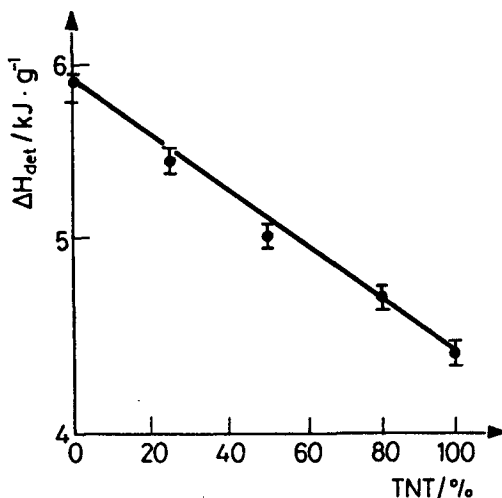

Fig. 3 Relationship between heats of detonation of TNT/RDX explosive mixtures and percentage TNT content

Figures 2 and 3 yielded the linear accumulation relationship between the heat of detonation of a charge and its composition:

$$Q = \sum Q_i m_i \quad (2)$$

where Q heat of detonation of explosive;
 Q_i heat of detonation or characteristic heat of i -th component;
 m_i mass percent of i -th component.

A series of experiments confirmed the above relationship for explosive-explorative mixtures and explosive-inert material mixtures (for inert materials such as graphite, aluminium, wax, etc.). Thus, the heat of detonation of the charge could be calculated via Eq. (2), if the heat of detonation and characteristic heat for each component have been obtained. Through density adjustment, the error of heat was less than 3%.

Table 4 Heats of detonation of some high explosives

Explosives	Density/ g·cm ⁻³	Heath of detonation $\Delta H_{det}H_2O(1) / \text{kJ}\cdot\text{g}^{-1}$	
		This work	Literature*
TNT	1.58–1.59	4.40	4.56
RDX	1.64–1.66	5.81	
HMX	1.81	6.02	6.19
PETN	1.57	6.24	6.23
DATB		4.16	4.10
PBXN-5	1.76	5.71	
LX-07	1.80	5.59	
LX-04	1.74	5.45	5.48
LX-11	1.69	5.19	5.15
O/F	1.40	4.42	
C-4		5.21	
Pentolite	1.65	5.38	5.15
Cyclotol 75/25	1.65	5.39	
Cyclotol 50/50	1.63	5.01	
Cyclotol 20/80	1.61	4.69	
Rubber explosive	1.27	4.63	
Hexal	1.94	7.42	
HVG-16	1.78	5.41	
Thermoset explosive	1.66	5.33	
Desensitized RDX	1.65	5.80	

*Obtained from measurements in wich a gold cylinder was used [19].

Conclusions

1. This newly-designed adiabatic detonation calorimeter measured the heat of detonation of the charge exactly.

2. The inert metal cylinder could be replaced by a cheap and less damaging porcelain cylinder.

3. There is a linear accumulation relation between the heats of detonation of explosive mixtures and their components. The heats of detonation of explosive mixtures could therefore be calculated from the heats of detonation of simple explosives and characteristic heats of other components.

* * *

We express out thanks to Professor Hu Rongzu for his help in this work.

References

- 1 A. Ya. Apin and Yu. A. Lebedev, Dokl. Akad. Nauk SSSR, 114 (1957), in Russ.
- 2 V. I. Pepekin, M. N. Makhov and Yu. A. Lebedev, Dokl. Akad. Nauk SSSR, 232 (4) (1977) 852, in Russ.
- 3 Yu. A. Lebedev, G. G. Lipanin, V. I. Pepekin and A. Ya. Apin, Vzryvnoe Delo, Nauchn-Tekhn. Gorn. Obschestro, Su. No. 52 /9 (1963) 80-90, in Russ.
- 4 D. L. Ornellas, J. C. Carpenter and S. R. Gunn, Rev. Sci. Inst., 37 (1966) 907.
- 5 D. L. Ornellas, J. Phys. Chem., 72 (1968) 2390.
- 6 D. L. Ornellas, Combust. Flame, 23 (1974) 37.
- 7 D. L. Ornellas and R. R. McGuire, UCID-18211 (1979).
- 8 R. R. McGuire, D. L. Ornellas and I. B. Akst, Procellants and Explosives, 4 (1979) 23.

Zusammenfassung — Mittels eines von den Autoren konstruierten adiabatischen Detonationskalorimeters wurde die Detonationswärme von 20 einfachen hochbrisanten Explosivstoffen und Explosivstoffgemischen ermittelt. Die Ergebnisse ergaben, daß der Einsatz des Gerätes zuverlässig ist und die experimentellen Daten sehr genau sind. Bei Explosivstoffgemischen ergab sich für die Detonationswärme ein linearer additiver Zusammenhang zwischen der Detonationswärme der Gemische und der Komponenten. Demzufolge kann die Detonationswärme von Explosivstoffgemischen direkt aus der Detonationswärme der einzelnen Explosivstoffe und der charakteristischen Wärme der anderen Komponenten errechnet werden. Die Versuche erwiesen, daß der Gold- oder Messingmantel des zylindrischen Gerätes durch einen kostengünstigeren dickwandigen Porzellanmantel ersetzt werden kann.